

Made by LAFUENTE (SPAIN)
 Tlf. (+34) 952 625 840
 www.lafuente.eu

Eg 55R -01 2517

TIPO EE0587 D 7,65 kN

CLASE A-50X S 85 kg

E9*55R01/08*2517*00

Made by LAFUENTE (SPAIN)
 Tlf. (+34) 952 625 840
 www.lafuente.eu

Eg 55R -01 2518

TIPO EE1587 D 7,65 kN

CLASE A-50X S 85 kg

E9*55R01/08*2518*00

Made by LAFUENTE (SPAIN)
 Tlf. (+34) 952 625 840
 www.lafuente.eu

Eg 55R -01 2519

TIPO EE4587 D 7,65 kN

CLASE A-50X S 85 kg

E9*55R01/08*2519*00

C		S		D	
	1.505 kg.		85 kg.		7,65 kN



ECE R55
homologación

ELEMENTOS DE UNIÓN / CONNECTION COMPONENTS / ELEMENTOS DE UNIÃO ÉLÉMENTS DE RACCORD / DAZUGEHÖRENDE TEILEN

BOLA / BALL / BOLA / ROTULE / KUGEL		VEHÍCULO / VEHICLE / VEÍCULO / VÉHICULE / FAHRZEUG	
		c	2 x M6x15 DIN 6921 8.8
		d	6 x M10x35 DIN 933 8.8
		e	4 x M12x40 DIN 933 8.8
a	2 x M12x65 DIN 931 8.8	f	2 x M6 DIN 6923 8
b	2 x M12 DIN 985 8	g	4 x M10 DIN 985 8
		h	2 x M10 DIN 125 -
		i	2 x M10 DIN 6798 -
a	4 x M12x25 DIN 933 8.8	j	4 x M12 DIN 6798 -
b	4 x M12 DIN 125 -	k	4 x M12 DIN 9021 -
		w	1 x M10x30 DIN 933 8.8
		x	1 x M10 DIN 985 8
		y	2 x M10 DIN 125 -
a	4 x M12x 25 DIN 933 8.8	z	1 x M10 DIN 2093 -
b	4 x M12 DIN 127 -		

Par de apriete para los tornillos/Tightening torque for bolts/Binário de aperto para os parafusos/
 Couple de serrage pour vis/Schrauben Drehmoment

Und.Nm	M6	M8	M10		M12			M14		M16
calidad/pase	1	1,25	1,5	1,25	1,75	1,5	1,25	1,75	1,5	2
8.8	11,3	27,3	54,0	57,0	93,0	97,0	101,0	148,0	159,0	230,0
10.9	16,5	40,1	79,0	83,0	137,0	143,0	149,0	218,0	234,0	320,0
12.9	19,3	46,9	93,0	98,0	160,0	167,0	174,0	255,0	274,0	395,0

HERMANOS SÁNCHEZ-LAFUENTE, S.A.

No asume ningún tipo de responsabilidad por daños causados por usos inadecuados.
 Assumes no responsibility for damage caused by misuse.
 Não assume qualquer responsabilidade por danos causados por utilização indevida.
 Decline toute responsabilité en cas de dommages causés par une mauvaise utilisation.
 Übernimmt keine Verantwortung für Schäden, die durch Missbrauch verursacht werden.



Este documento debe ser presentado en la I.T.V. junto con el certificado de montaje.
 Comprobar en el Certificado de Conformidad (COC) del vehículo las capacidades máximas de arrastre y carga vertical.
 Check the vehicle's documentation for the maximum towing and vertical load capacities.
 Verificar no Certificado de Conformidade do veículo as capacidades máximas de reboque e carga vertical.
 Consultez la carte grise du véhicule pour connaître les capacités maximales de remorquage et de charge verticale.
 Überprüfen Sie die Fahrzeugdokumentation auf die maximale Anhängelast und Stützlast.



DACIA SANDERO (2020 - ...)



EE0587



EE1587



EE4587

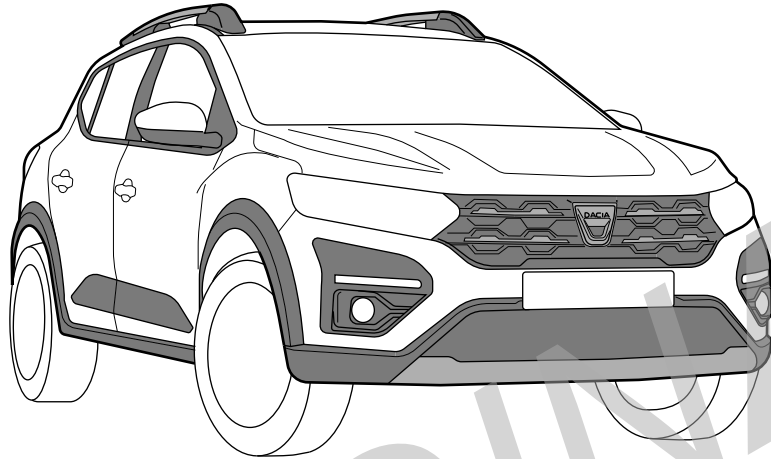

Instrucciones de montaje - Installation instructions - Instruções de montagem - Notice de montage - Montageanleitung

1

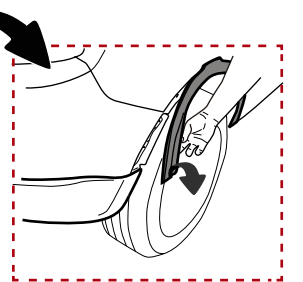
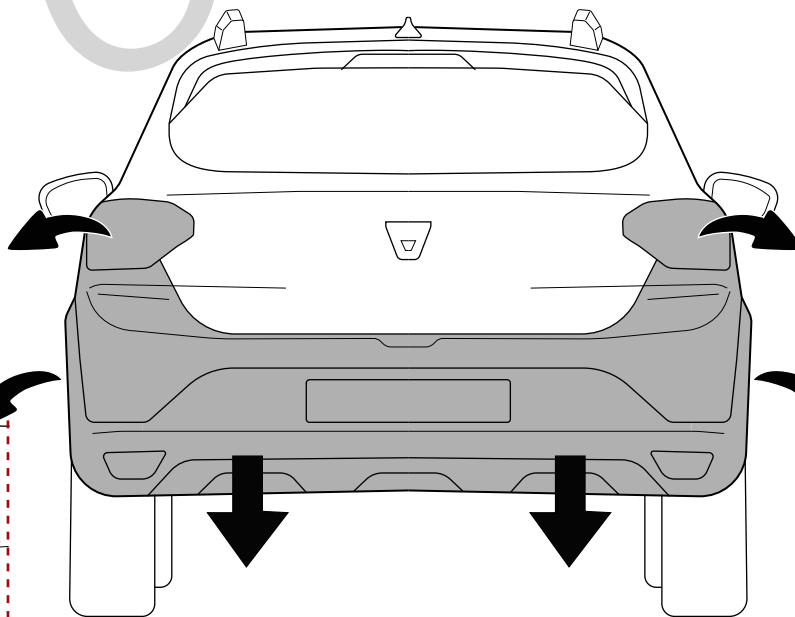
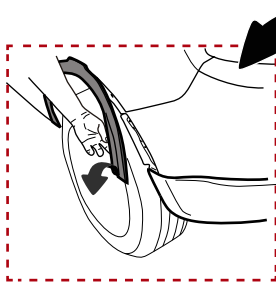
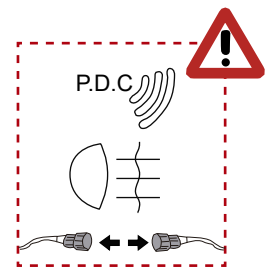
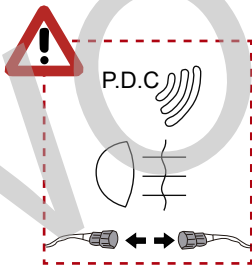

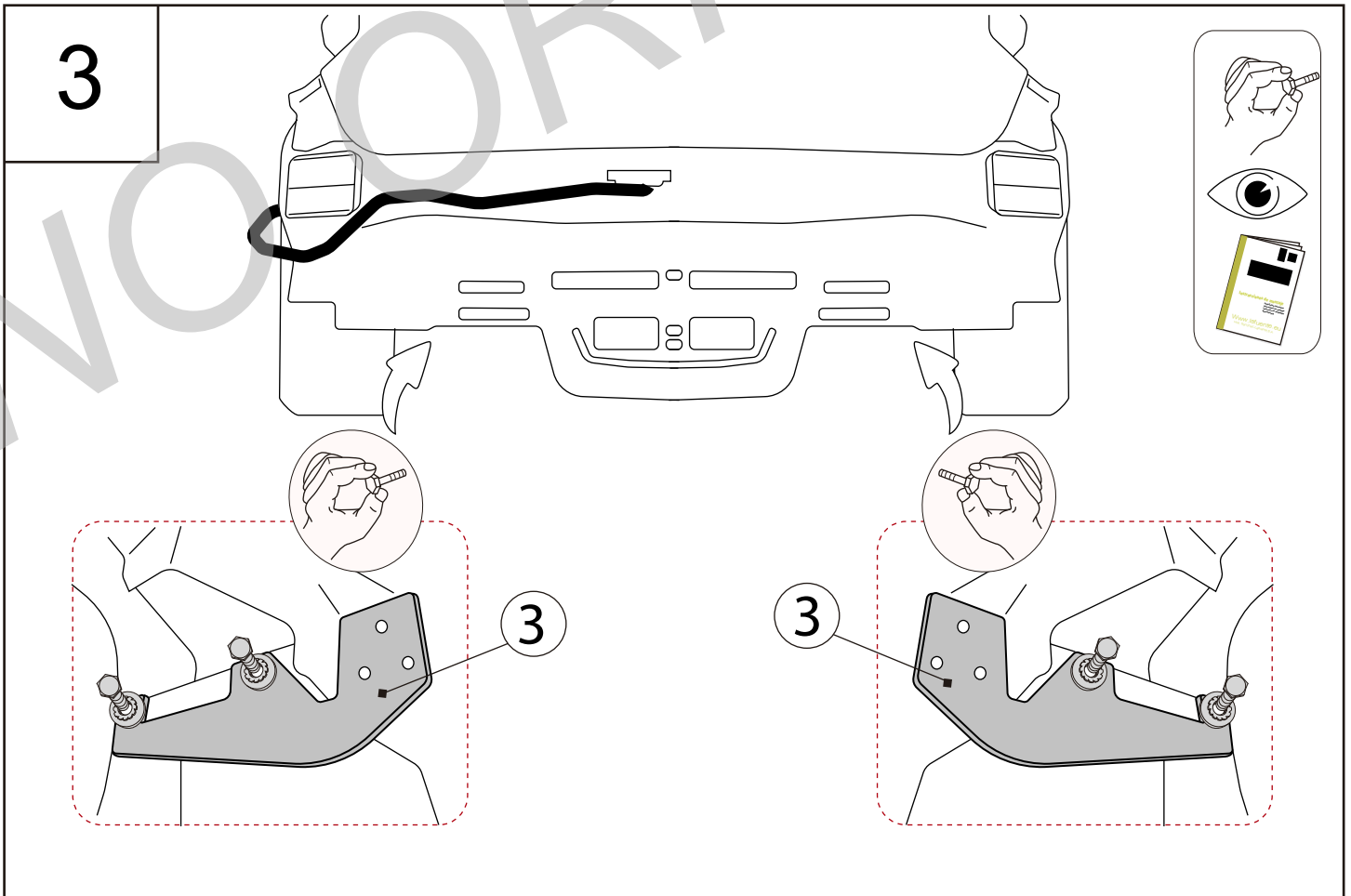
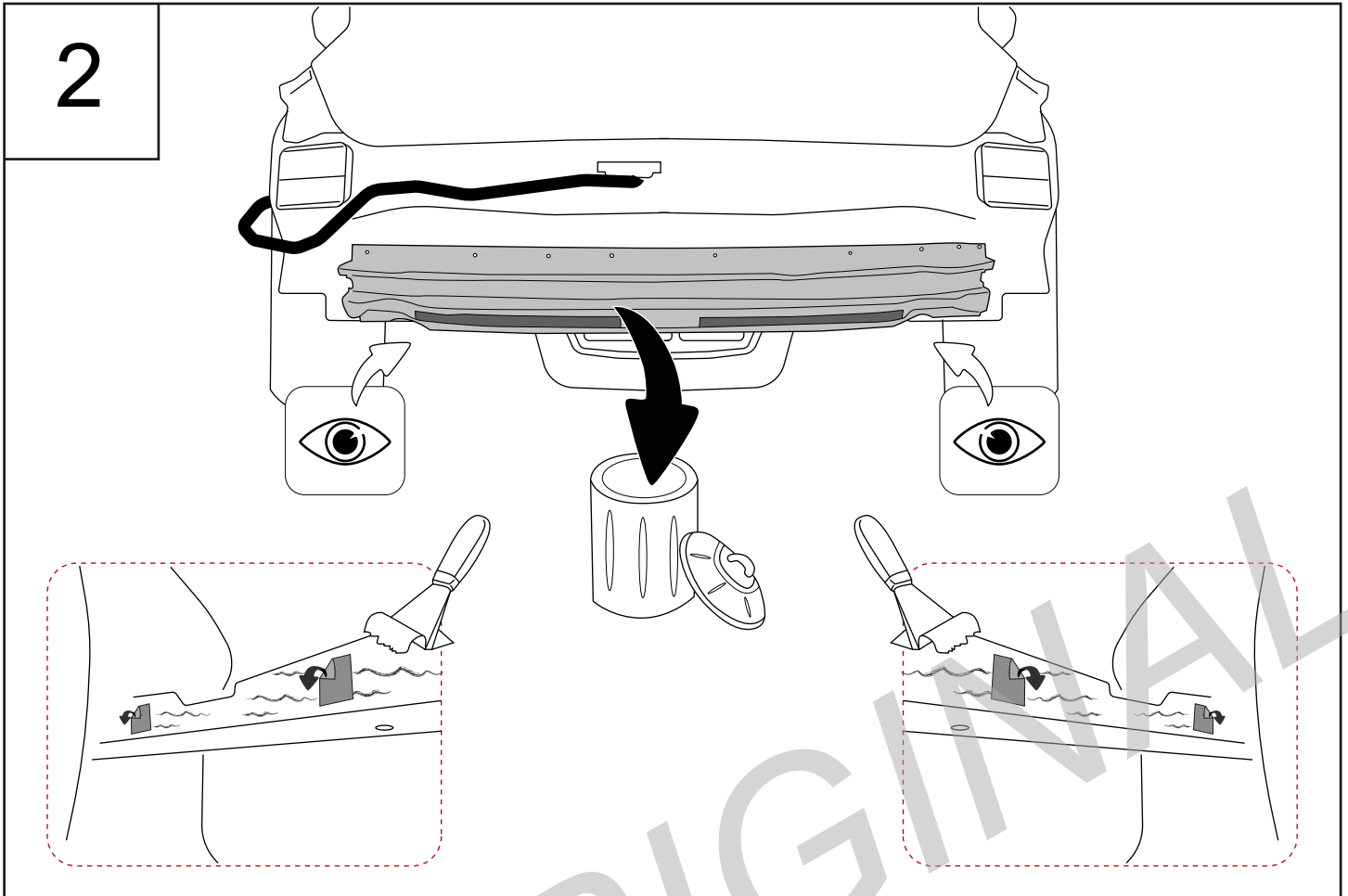

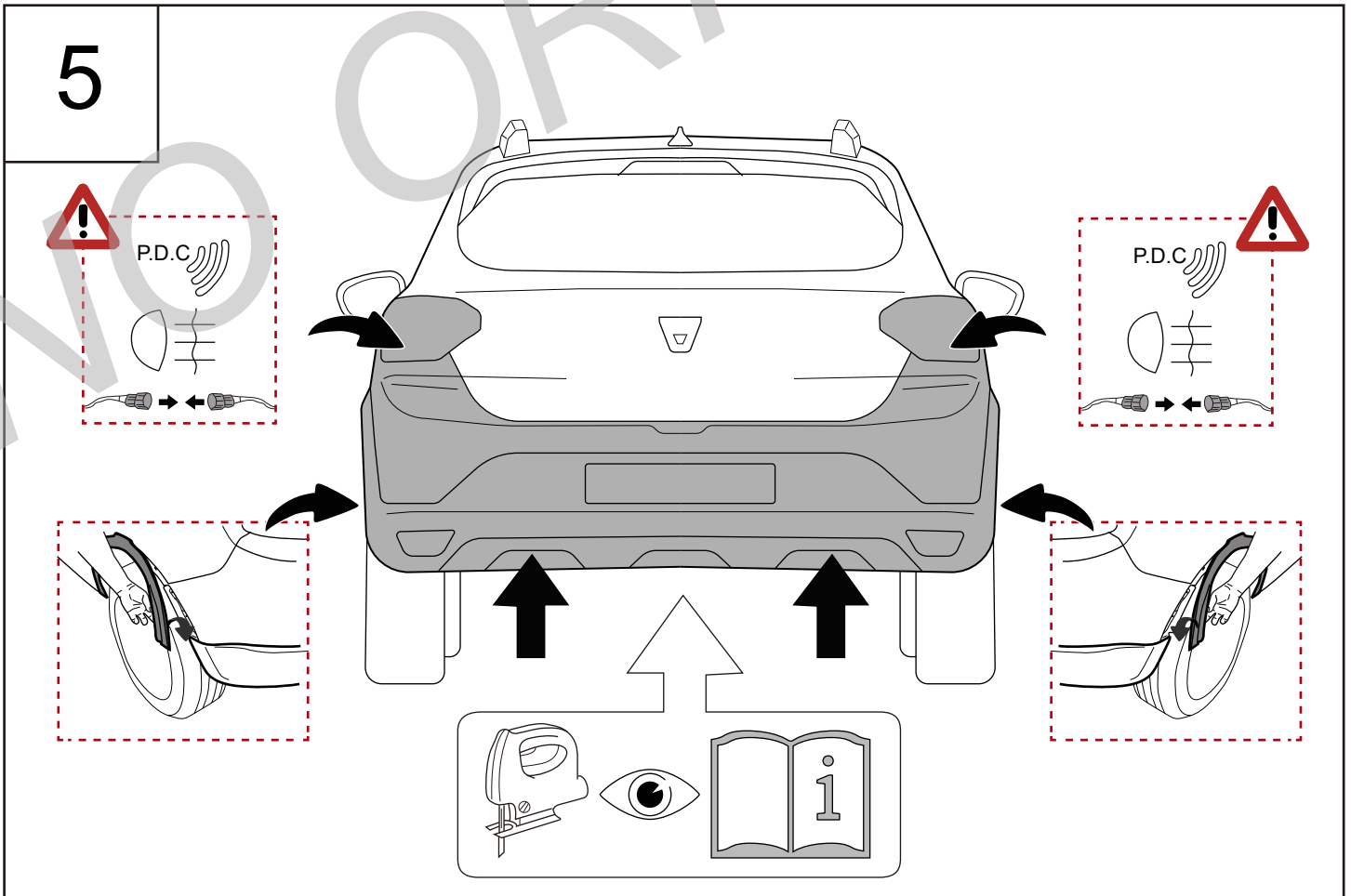
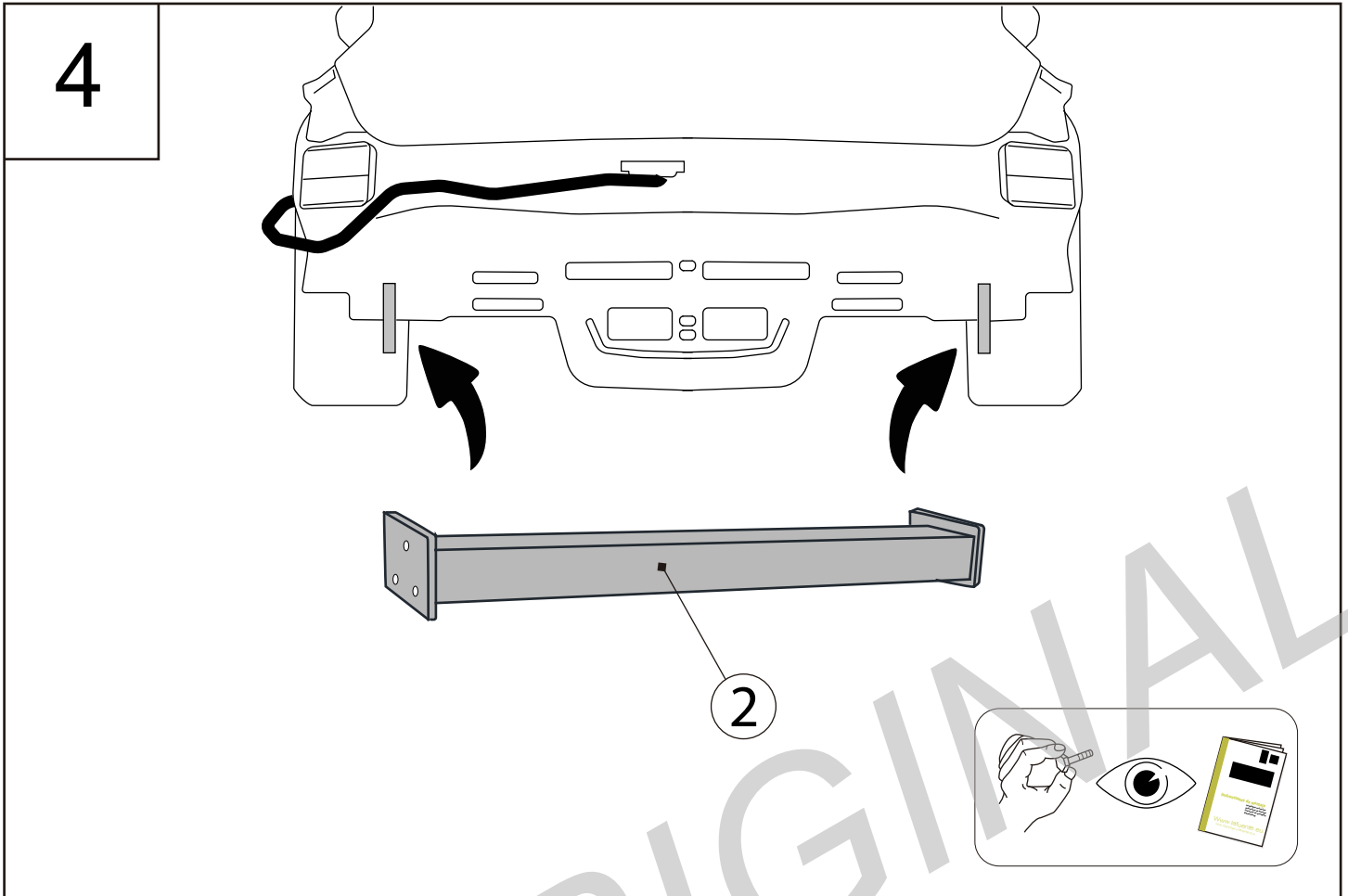

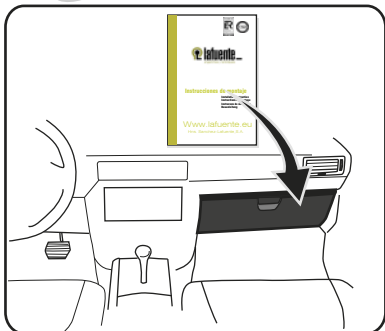
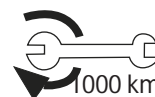

	M6	M8	M10	M12	M14	M16
8.8	10,4Nm	25,0Nm	51,0Nm	87,0Nm	140,0Nm	215,0Nm
10.9	15,5Nm	37,0Nm	75,0Nm	130,0Nm	205,0Nm	310,0Nm
12.9	18,0Nm	43,0Nm	87,0Nm	150,0Nm	240,0Nm	370,0Nm

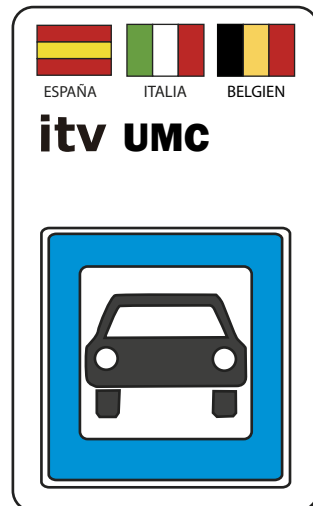
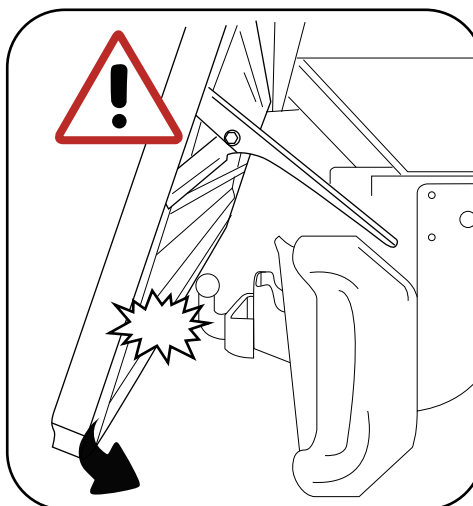
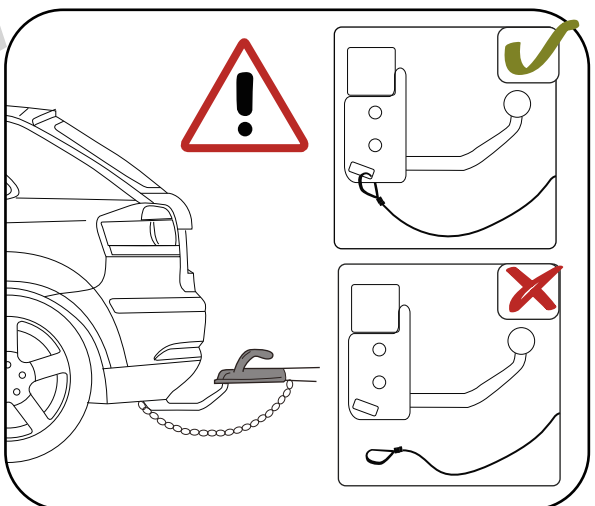
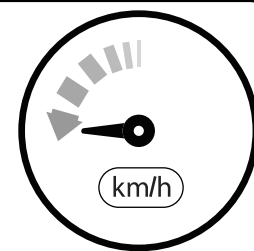
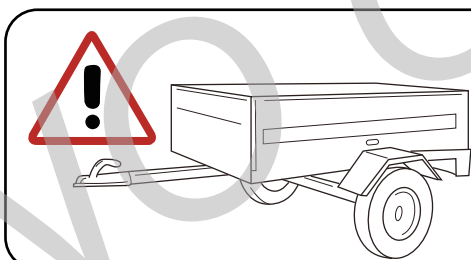
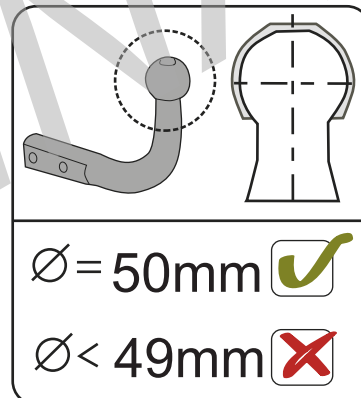
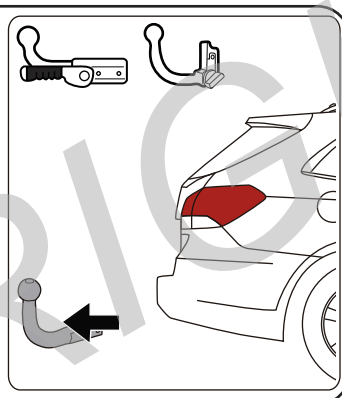
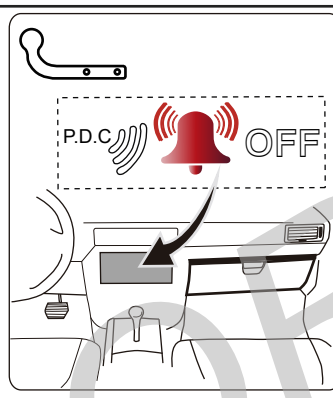
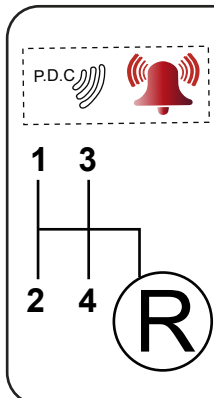
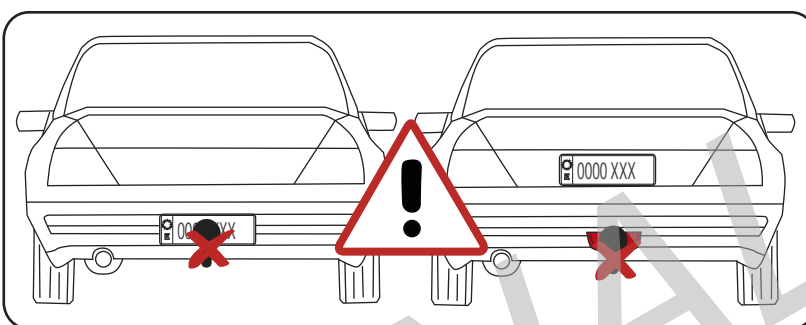
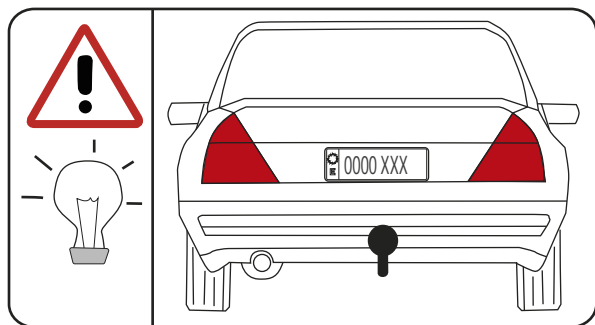

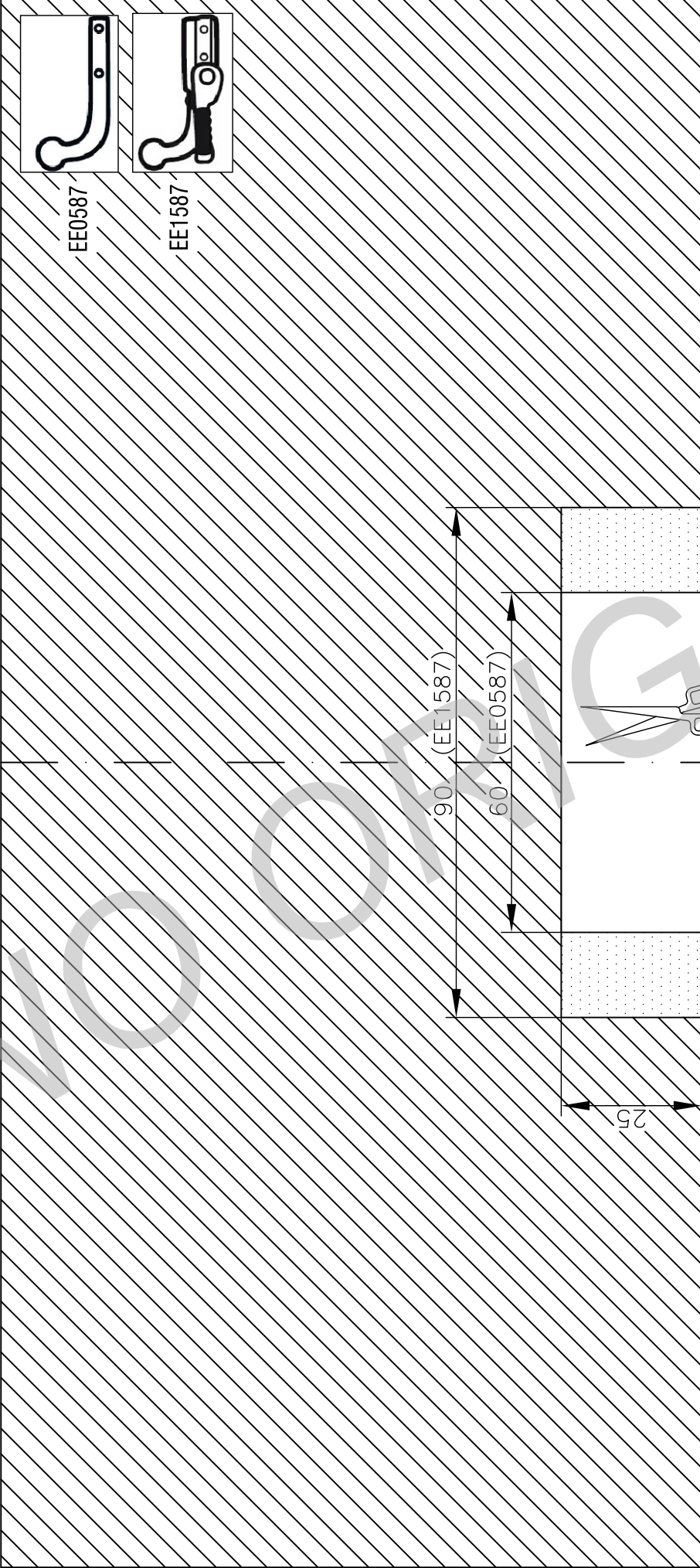

ESP: El corte es orientativo puede variar por modelo y año
 UK: The cut is indicative it can change for model and year
 PT: O corte é inidcativo. Pode variar segundo o modelo e ano.
 FR: La découpe est indicative et peut varier selon le modèle et l'année
 DE: Der Schnitt ist indikativ, er kann je nach Modell und Jahr variieren

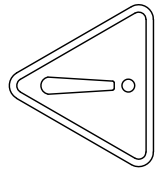

		DACIA SANDERO	
1:1	mm	EE0587-EE1587	Rev. P1

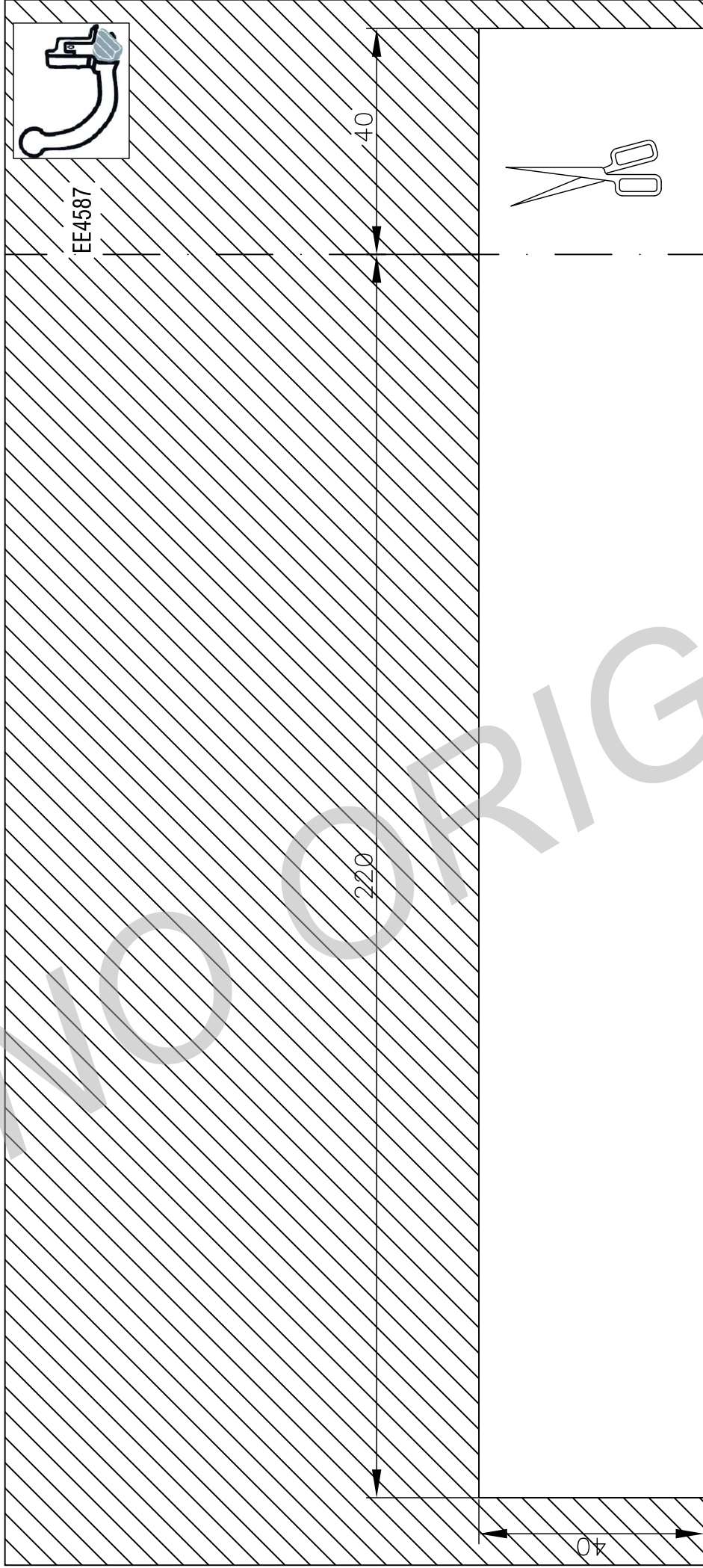

EE4587

220

40

40

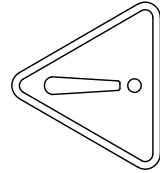
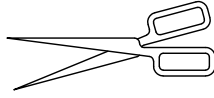

ESP: El corte es orientativo puede variar por modelo y año
 UK: The cut is indicative it can change for model and year
 PT: O corte é indicativo. Pode variar segundo o modelo e ano.
 FR: La découpe est indicative et peut varier selon le modèle et l'année
 DE: Der Schnitt ist indikativ, er kann je nach Modell und Jahr variieren



DACIA SANDERO

Rev. P1

EE4587

1:1

mm